

SPECIFICATION SHEET



pH TRANSMITTER

HDM-135A (2-wire system)
HDM-136A (4-wire system)

The pH transmitter is a user-friendly device that features a compact and robust aluminum case, making it ideal for on-site installation.

This device comes in two different models: the 2-wire system (24VDC power supply) and the 4-wire system (adjustable-voltage AC power supply).

Features

○ Automatic determination of electrode quality

The transmitter judges the electrode quality from its characteristics during calibration with standard solutions. Degradation of electromotive force at pH7, degradation of electromotive force per pH and other information is displayed in the form of error messages. Characteristic data of each electrode can be called out to determine the extent of degradation as required.

○ Output hold while performing maintenance work

When the transmitter enters maintenance (ST-BY) mode, the previous output value is held. This helps to prevent disruptions to the control system.

○ Measured value shift

Measured pH values can be shifted for operational control. (Shift width: $\pm 1.0\text{pH}$)

○ Manual temperature compensation

Manual temperature compensation function (0 - 100°C) can be provided for use with electrodes which do not have compensation functions.



○ pH temperature compensation

The transmitter compensates the pH temperature characteristics of samples (such as pure water and boiler water).

○ Setting range of temperature compensation coefficient : $\pm 0.1\text{pH}/^\circ\text{C}$

Standard conversion temperature: 25°C

○ Automatic reversion to measurement mode

The analyzer/transmitter automatically switches back to measurement mode if it is left in maintenance mode for more than two hours.

○ External input for "hold" feature (option)

The transmitter can receive a "hold" command signal from the cleaning devices to hold output during the cleaning.

System configuration

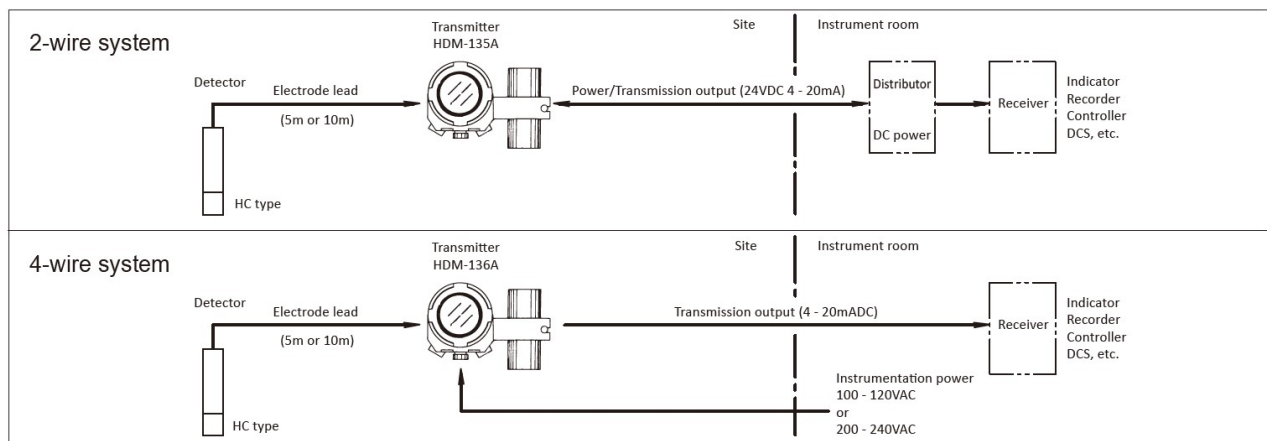

Standard Specifications

Product name	pH TRANSMITTER	
Model	HDM-135A (2-wire system)	HDM-136A (4-wire system)
Measurement range	pH: -1.00~14.00 (mV: -600~600 mV (Temperature: 0~100°C (Display only. No output-signal.)	
Display	Digital LCD	
Min. Indication	pH: 0.01, mV: 0.1, Temperature: 0.1°C	
Performance (excluding detector)	Linearity	Within ±0.03pH (at equivalent input)
	Repeatability	Within ±0.02pH or less (at equivalent input)
Transmission Output	4~20mA DC, isolated. type Load resistance MAX 650Ω or less.	
Transmission Output Range	Adjustable range between -1 to 14 pH steps with minimum width of 2 pH.	
Power supply	24VDC ±10%	90~132VAC 50/60Hz or 180~264VAC 50/60Hz (option)
Power consumption	0.6VA or less	Approx. 3VA
Ambient conditions	-20~55°C, 99% (RH) or less (no condensation)	
Construction	Outdoor installation, IP55 (dust/jet-proof type)	
Dimensions	118 (W) x 129 (H) x 178 (D) mm	
Mounting	Mounted on 50A pipe	
Weight	Approx. 3.5kg	
Cable entry	G 3/4 (PF 3/4 F), 3 ports	
Materials	Main body	Cast aluminum alloy
	Window	Resin
	Mounting bracket	SUS 304
Color	Metallic silver and blue	

Control switch/Display

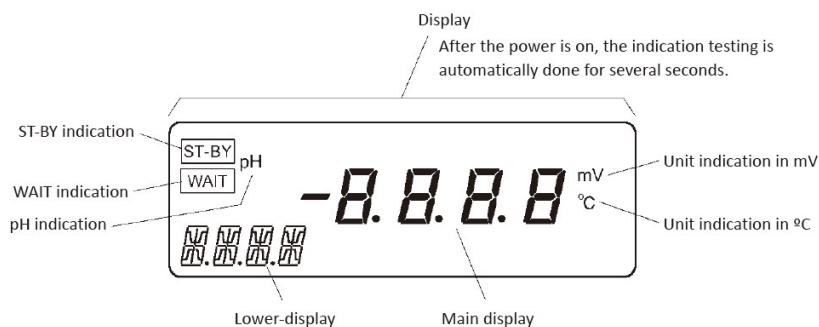
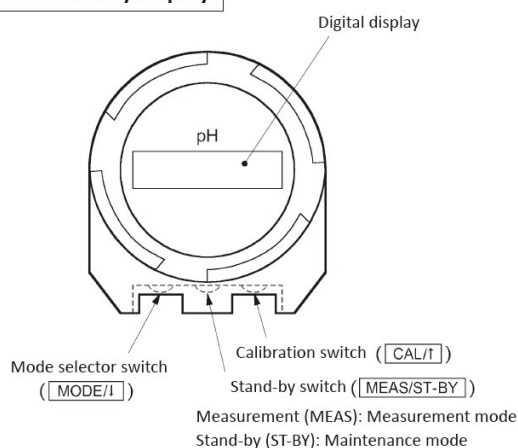

Terminals

● HDM-135A (2-wire system)

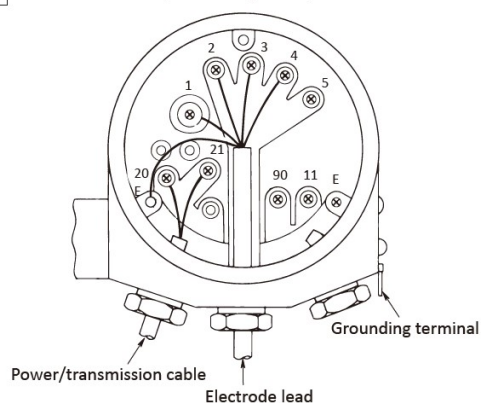

● HDM-136A (4-wire type)

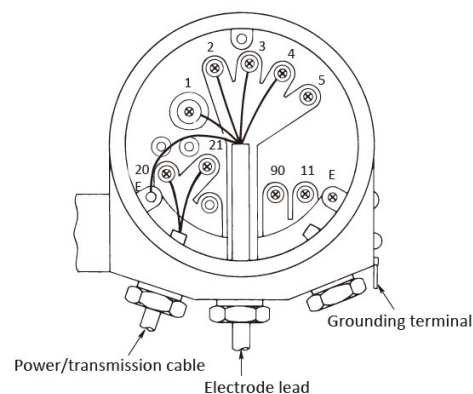

Dimensions

Unit : mm

● HDM-135A/136A

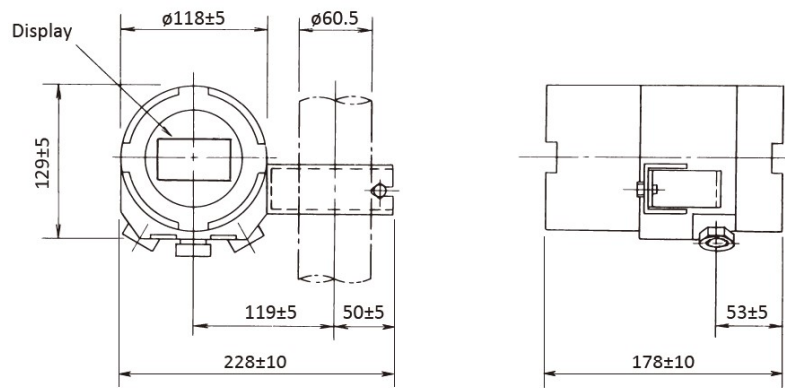

● HDM-135A (2-wire system)

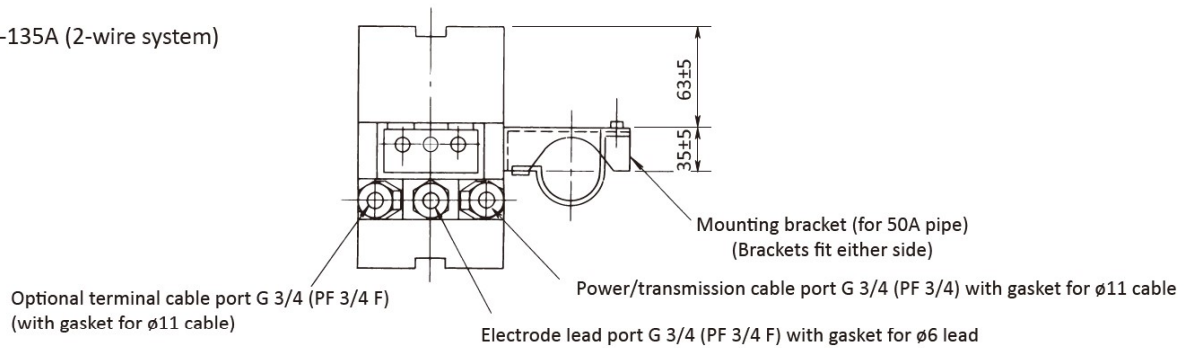

● HDM-136A (4-wire system)

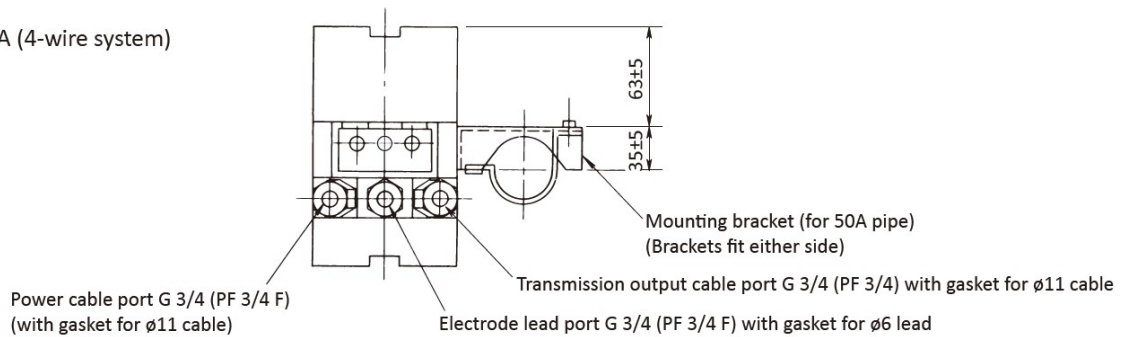

● Hood (option)

Recommended when installing the instrument in a location exposed to direct sunlight.

- Material : SUS304
- Mounting : Mounted on 50A pipe
- Code Number : 544493K

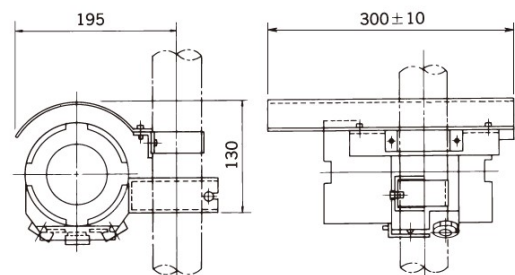

Wiring diagrams for 2-wire system

<When electrode is directly connected to transmitter>

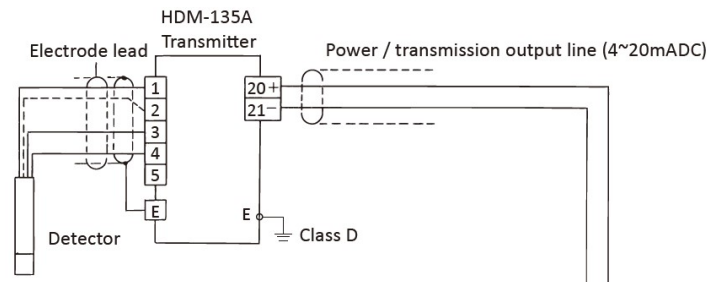

<When the electrode is connected via a junction box and extension cable>

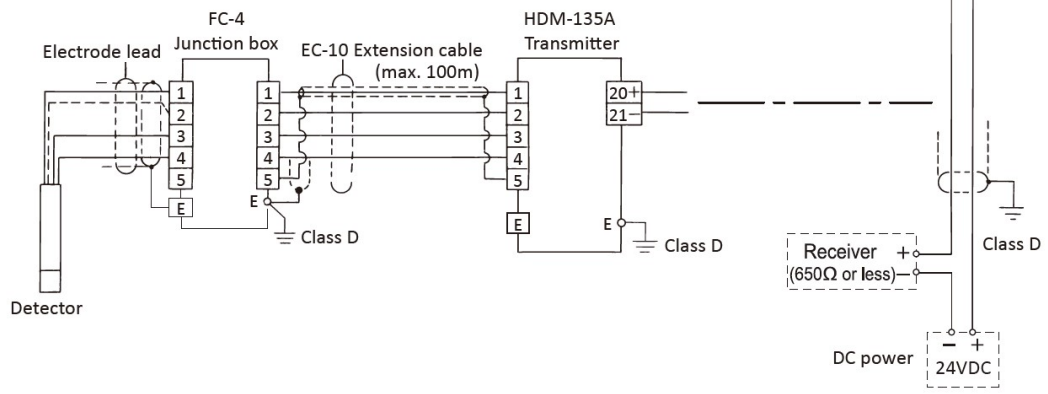

<Wiring example when using the device together with a RHC-7C chemical cleaner>

When the transmitter is equipped with the external input for the output hold command (terminals #90 - #11 (option))

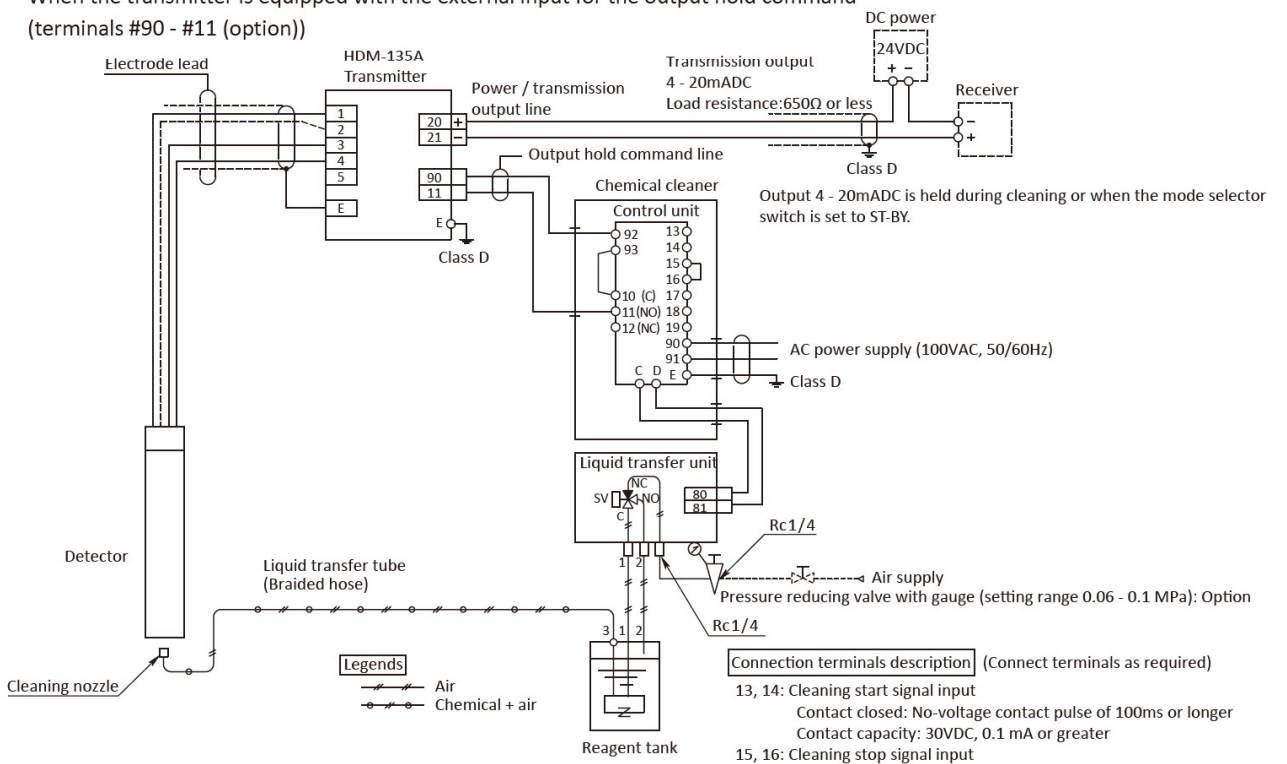

Legends

- Air
- Chemical + air

Connection terminals description (Connect terminals as required)

- 13, 14: Cleaning start signal input
Contact closed: No-voltage contact pulse of 100ms or longer
Contact capacity: 30VDC, 0.1 mA or greater
- 15, 16: Cleaning stop signal input
Stops when open (factory shipped with jumper across terminals)
Internal load: 100VAC, 220 mA (solenoid valve)
- 10, 11, 12: Cleaning signal 1 output
Contact across terminals #10 and #11 is closed during cleaning.
Contact capacity: 125VAC, 1A
- 17, 18, 19: Cleaning signal 2 output
Contact across terminals #17 and #18 is closed during cleaning.
Contact capacity: 125VAC, 1A

Wiring diagrams for 4-wire system

<When electrode is directly connected to transmitter>

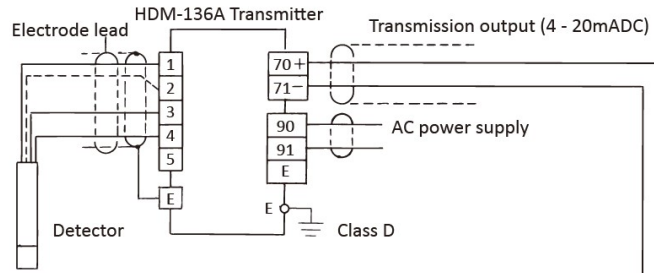

<When the electrode is connected via a junction box and extension cable>

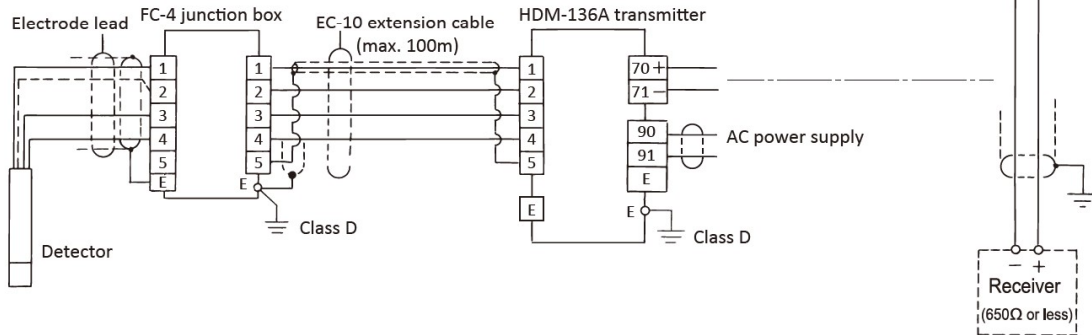

<Wiring example when using the device together with a RHC-7C chemical cleaner>

When the transmitter is equipped with the input for the external output hold command (terminals #10 - #11 (option))

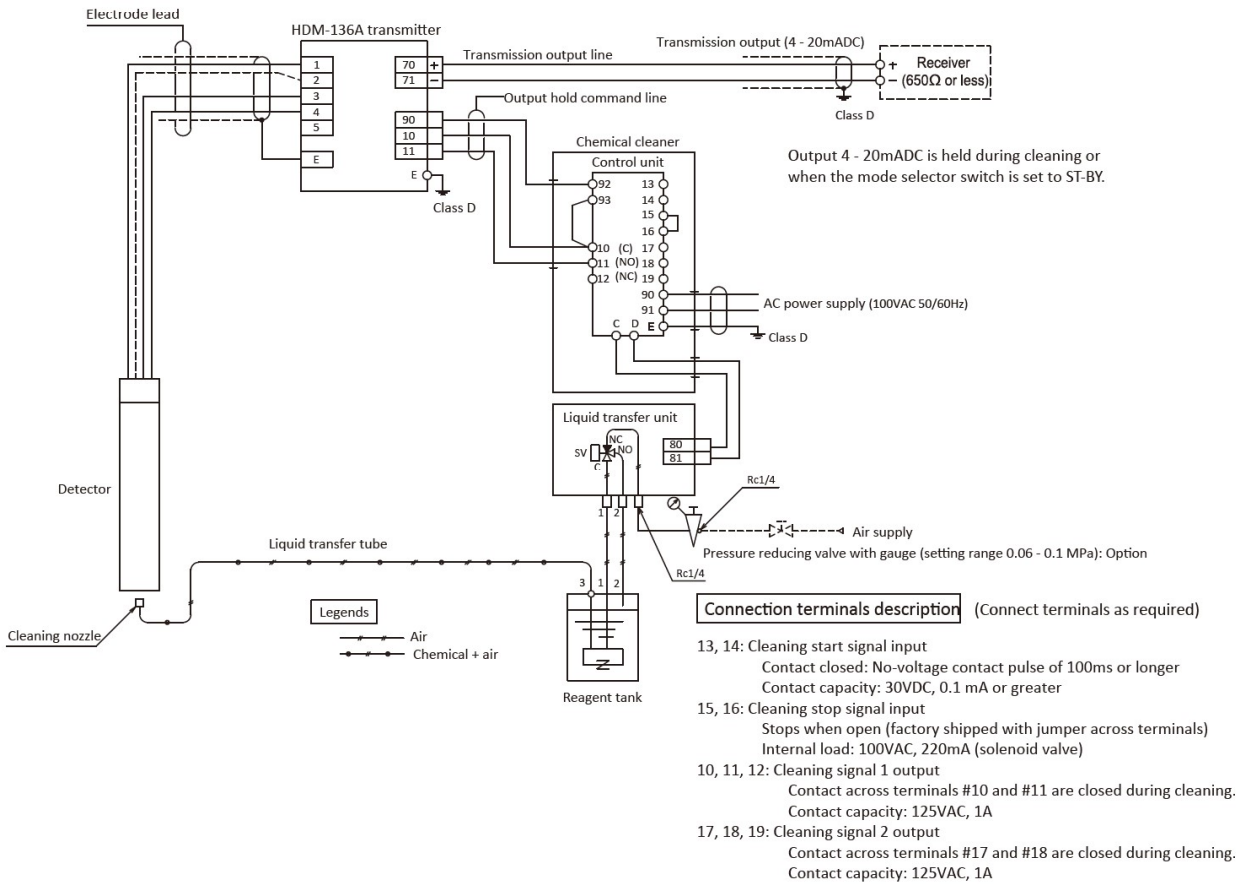

Related equipment

There are related optional products for HDM-135A/136A. Order separately as necessary.

● Junction box and Extension cable

Junction box and Extension cable are required when the transmitter and electrode are installed away from each other and the standard electrode lead length (5m) is too short. Both of them are special high insulating shield

Model	: FC-4
Construction	: Outdoor installation
Mounting	: 25 - 50A pipe, wall or panel mount
Material	: ABS resin
Finish	: Pearskin finish chromium plating
Weight	: Approx. 0.9kg

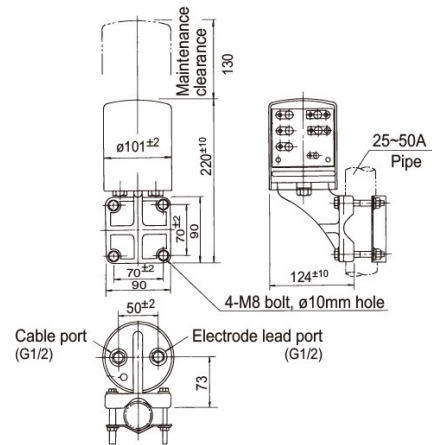

● Sensor Cable

Model	: EC-10
Outer Diameter	: $\phi 8$ mm
Insulation	: Polyethylene and vinyl
Casing	: Vinyl
Insulation resistance between core wires	: At least $10^9 \text{M}\Omega / 100\text{m}$
Extension distance	: Maximum length of 100m, intermediate connection cannot be used
Standard length	: 5m to 50m in 5-meter units
Weight	: Approx. 0.5kg / 5m

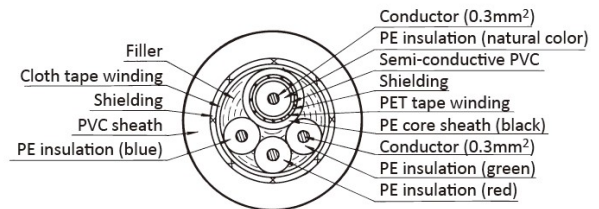

● Power supply unit

A power supply unit (24VDC) for the 2-wire type HDM-135A.

Model	: PA-24
Output voltage rating	24VDC+3/-1V
Output current rating	2 - 22mA (Parallel connection between two instruments cannot be made.)
Power requirements	: 100VAC±10%, 50/60Hz
Ambient conditions	: -5 - 55°C
Construction	: Indoor installation, plug-in type
Weight	: Approx. 300g

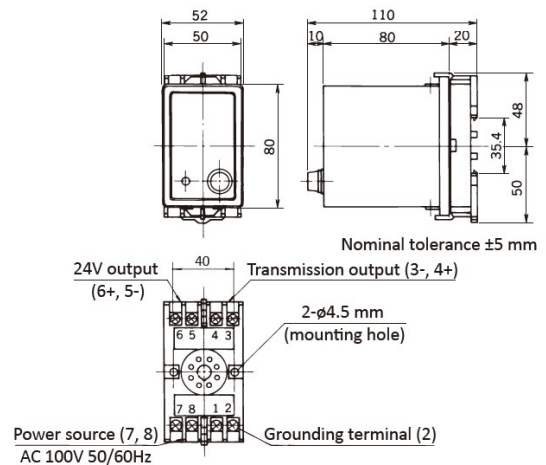

Supported detectors

Supported detectors can be used together with HDM-135A/136A controller, as shown in the following table. Select the detector that best fits the immersion type, flow-through type, material and measurement conditions.

● Detectors for replaceable-tip electrodes

Classification		Application	Model	Wetted part material	pH electrode
KCl Refillable	Immersion type	General use (below 60°C)	HC-G70	PVC	GSS-314B (general use) GSS-314A (high alkali resistant) GSS-314F (hydrofluoric acid resistant)
		High temperature (below 80°C)	HC-G70	PP	
	Flow-through type	General use, pressurized type (below 60°C)	HC-G80P	PVC	
		High temperature, pressurized type (below 80°C)	HC-G82P	PP SUS316	
Micro flow rate type		For boiler and pure water	HC-G65	Acrylic	GSS-314P
KCl Replenish-Free	Immersion type	Effluent treatment (below 60°C)	HC-G70	PVC	GSS-304B (general use) GSS-304A (high alkali resistant) GSS-304F (hydrofluoric acid resistant)
		High temperature effluent treatment (below 80°C)	HC-G70	PP	
			HC-G72	SUS316	
	Effluent treatment, drop-in type	HC-G95	PVC SUS316		
	Flow-through type	Effluent treatment (below 60°C)	HC-G80	PVC	
High temperature effluent treatment (below 80°C)		HC-G82	PP SUS316		

● Detectors for integrated (conventional) KCl refillable type electrodes

Classification		Application	Model	Wetted part material	pH electrode
Immersion type		General process/effluent treatment (below 60°C)	HC-703C	PVC	5600 (general use) 5605 (hydrofluoric acid resistant)
		High temperature process (below 80°C)	HC-763	PP	5601
		High temperature process, chemical resistant	HC-703F	PVDF	5601
		High temperature process, organic solvent resistant	HC-703T	PFA PTFE	5602
Flow-through type		General process use/effluent treatment, insertion type, pressurized type	HC-880	PP or PVC	5610 (normal temperature)
		General process use/effluent treatment, pressurized type, supplied with PP or PVC case	HC-882	PP or PVC	5611 (high temperature)
		General process use/effluent treatment, pressurized type, supplied with SUS case	HC-883	PP or PVC SUS316	



DKK-TOA CORPORATION



CAUTION

Please read the operation manual carefully before using products.

Overseas Sales Division:
DKK-TOA Corporation
29-10, 1-Chome, Takadanobaba, Shinjuku-ku,
Tokyo 169-8648 Japan
Tel : +81-3-3202-0225 Fax : +81-3-3202-5685

<http://www.toadkk.co.jp/english>

Information and specifications are subject to change without notice.